

Changed make From Rev C to D :
 1 Adding USB section .
 2 Change power supply pin P13 & P14 from 1.8v to 3.3v
 3 Change resistors size to be smaller and closer to the pins R20, R21, R22, R23, R24, R37 and R45

C:\DOCUMENTS AND SETTINGS\MICHAEL\MYM\DOCUMENTS\EXAR\REVAL BOARD SCHEMATIC\91L80\REVISED BOARD\T91L80.DSN

EXAR CORPORATION		
XRT91L80 - Interface & Control		
Size C	Document Number OC48 TRANSCEIVER	Rev 0
Date: Tuesday, July 25, 2006	Sheet 1 of 2	

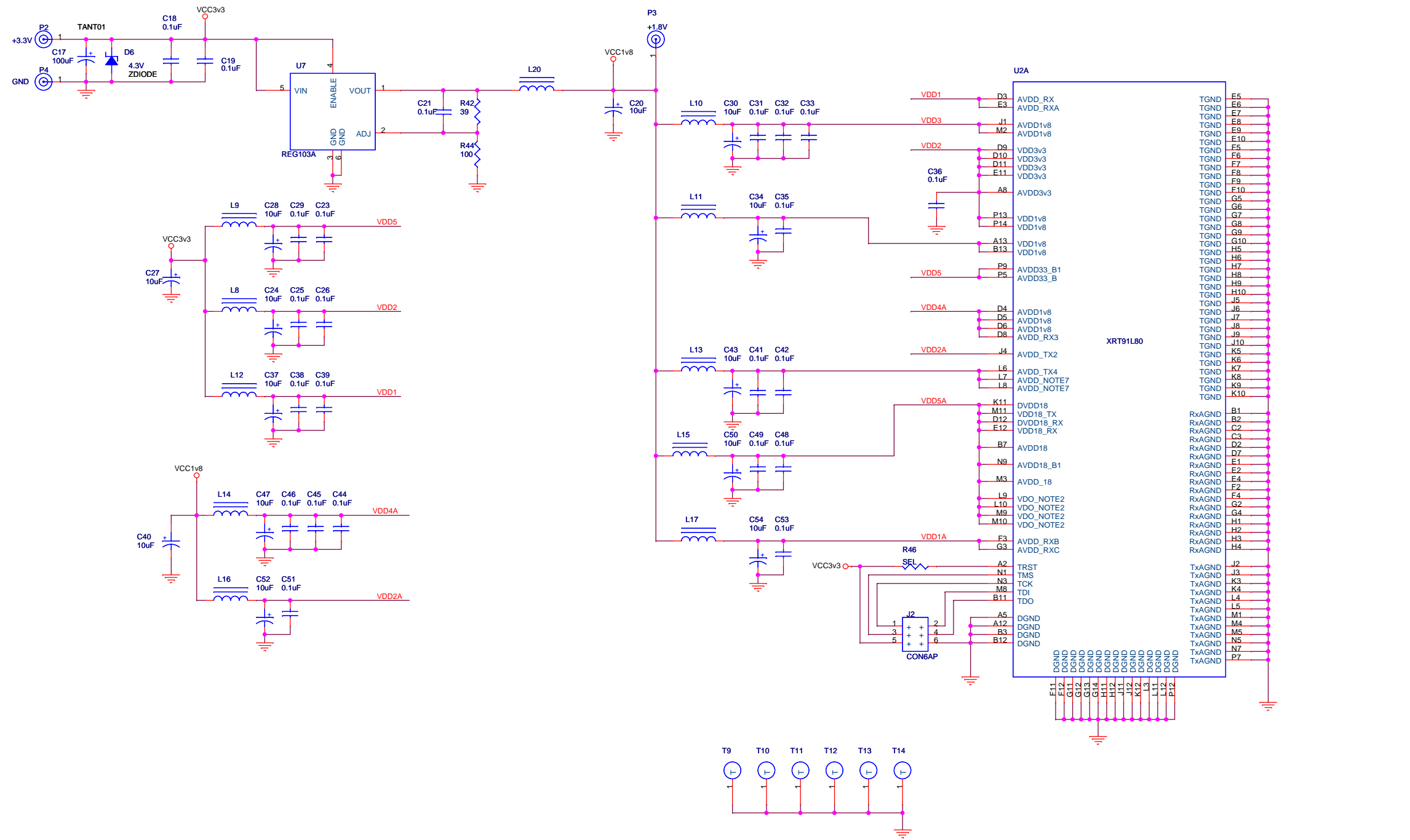

EXAR CORPORATION		
Title XRT91L80 Power Distribution		
Size C	Document Number OC48 TRANSCEIVER	Rev 0
Date: Wednesday, July 19, 2006	Sheet 2 of 2	